

# POWER ELECTRONICS TRAINER

## EM-21800QM



Power Electronics has evolved from static converter technology into a significant field within electrical engineering and electronics. By using power semiconductors power electronics performs such functions as switching, controlling and converting of electrical energy with the greatest possible efficiency. One area of application for power electronics is drive technology. Here, speed variable DC and three-phase four-quadrant drives can easily be realized using modern power electronics. As a result of this development we can no longer imagine industry, workshop tools, commercial enterprises and household appliances without thyristor speed control units, smooth-starting circuits, frequency converters etc. The EDULAB DIDACTIC training panel system EM-21800QM for power electronics and drive now makes it possible to convey the technical knowledge of this field.

The experiments permit practice-oriented, hands-on training to be carried out, thus assuring the trainees of the proficiency needed to handle the tasks and the equipment found in this field. The training panels and functional units with block circuit diagrams and signal diagrams permit clear and understandable assembly of the experiment circuits. Beginning with the basic circuits, the student proceeds to tackle more complex circuits in power electronics and drive technology using a proven step-by-step method designed for didactic results. And of course, the model behind the entire system is the circuitry used in industrial applications.

## **Experiments cover the following topics:**

### **Section 1: Diode and Uncontrolled Rectifier Circuit (AC-DC Conversion)**

- 1-1 Power Diode
- 1-2 Single Phase Half Wave Rectifier Circuit
- 1-3 Full Wave Rectifier Circuit with Center Tap Transformer
- 1-4 Single Phase Full wave Bridge Rectifier Circuit
- 1-5 Three Phase Half Wave Rectifier Circuit
- 1-6 Three Phase Full Wave with Center Tap Transformer Rectifier Circuit
- 1-7 Three Phase Full Wave Bridge Rectifier Circuit

### **Section 2: SCR and Controlled Rectifier Circuit (AC-DC Conversion)**

- 2-1 SCR and Single Phase Controller
- 2-2 Single Phase Half Wave Controlled Rectifier Circuit
- 2-3 Single Phase Full Wave Controlled Rectifier With Center Tap Transformer Circuit
- 2-4 Single Phase Bridge Full Wave Controlled Rectifier Circuit
- 2-5 Single Phase Full Wave Half Controlled Rectifier Circuit SCR based Inverters
- 2-6 Three Phase Half Wave Controlled Rectifier Circuit
- 2-7 Three Phase Full Wave Controlled Rectifier With Center Tap Transformer Circuit
- 2-8 Three Phase Bridge Full Wave Controlled Rectifier Circuit
- 2-9 Three Phase Full Wave Half Control Bridge Rectifier Circuit
- 2-10 Star-Delta Connections Control Rectifier Circuit

**2-11 Delta-Connected Three Phase Bi-direction Connection (Three Phase AC Motor Control)**

**2-12 Star-Connected Three Phase Bidirectional Connection (Three Phase AC Motor Control)**

### **Section 3: Thyristors and Controlled Circuit (AC-AC Conversion)**

- 3-1 Triac
- 3-2 Single Phase AC Voltage Control Circuit (On-Off Control)
- 3-3 Single Phase AC Voltage Control Circuit (Phase Control)
- 3-4 Three Phase Full Wave AC Voltage Control Circuit

### **Section 4: Chopper Circuit (DC-DC Conversion)**

- 4-1 PWM Generation and Gate Drive Circuit
- 4-2 IGBT Chopper / Inverter Circuit
- 4-3 MOSFET Chopper Circuit
- 4-4 Darlington Chopper Circuit
- 4-5 Hi-Bridge Converter
- 4-6 Hi-Bridge Converter DC Motor Control**
- 4-7 MOSFET DC Motor Control**
- 4-8 TRIAC DC Motor Control**

**EXPERIMENTS MODULE CONSISTS OF THE FOLLOWING:**

<p align="center"><b>GROUP OF DIODE MODULE EM-21-01-03</b></p>	<p align="center"><b>GROUP OF SCR MODULE EM-21-01-05 (2 UNITS)</b></p>
<div data-bbox="282 275 620 667" data-label="Image"> </div> <ul style="list-style-type: none"> <li>○ Device : Fast Acting Silicon Diode</li> <li>○ Quantity : 6</li> <li>○ Voltage : 500V</li> <li>○ Current : 15A</li> <li>○ Protection : 5A Fuse With Fuse Holder</li> <li>○ Terminal Socket : 4mm Safety Type</li> <li>○ Unit Type : Panel H2</li> </ul>	<div data-bbox="1013 275 1351 674" data-label="Image"> </div> <ul style="list-style-type: none"> <li>○ Device : Silicon Control Rectifier</li> <li>○ Quantity : 6</li> <li>○ Voltage : 600V</li> <li>○ Current : 15A</li> <li>○ Protection : 5A Fuse With Fuse Holder</li> <li>○ Terminal Socket : 4mm Safety Type</li> <li>○ Unit Type : Panel H2</li> </ul>
<p align="center"><b>TRIAC MODULE EM-21-01-06</b></p>	<p align="center"><b>POWER MOSFET MODULE EM-21-01-10</b></p>
<div data-bbox="315 1115 587 1593" data-label="Image"> </div> <ul style="list-style-type: none"> <li>○ Device : TRIAC</li> <li>○ Quantity : 1</li> <li>○ Voltage : 600V</li> <li>○ Current : 15A</li> <li>○ Protection : 5A Fuse With Fuse Holder</li> <li>○ Terminal Socket : 4mm Safety Type</li> <li>○ Unit Type : Panel H1</li> </ul>	<div data-bbox="1052 1115 1318 1570" data-label="Image"> </div> <ul style="list-style-type: none"> <li>○ Device : Power Field Effect Transistor (N-Channel Enhancement Mode Silicon Gate)</li> <li>○ DC Input Voltage : Maximum 220V</li> <li>○ DC Output Current : Maximum 5A</li> <li>○ Switching Frequency : 0...15KHz</li> <li>○ Quantity : 1</li> <li>○ Voltage : 600V</li> <li>○ Current : 15A</li> <li>○ Protection : 5A Fuse With Fuse Holder</li> <li>○ Terminal Socket : 4mm Safety Type</li> <li>○ Unit Type : Panel H1</li> </ul>

**DARLINGTON TRANSISTOR MODULE  
EM-21-01-12**



- Device : Darlington Transistor
- DC Input Voltage : Maximum 220V
- DC Output Current : Maximum 5A
- Switching Frequency : 0...15KHz
- Quantity : 1
- Voltage : 600V
- Current : 15A
- Protection : 5A Fuse With Fuse Holder
- Terminal Socket : 4mm Safety Type
- Unit Type : Panel H1

**IGBT CHOPPER / INVERTER MODULE  
EM-21-01-13**



- Device : Silicon Insulated Gate Bipolar Transistor (N-Channel Enhancement Mode Silicon)
- DC Input Voltage : Maximum 220V
- DC Output Current : Maximum 5A
- Switching Frequency : 0...15KHz
- Quantity : 6
- Voltage : 600V
- Current : 15A
- Protection : 5A Fuse With Fuse Holder
- Terminal Socket : 4mm Safety Type
- Unit Type : Panel H2

**TWO PULSE CONTROLLER  
EM-21-02-01 (2 UNITS)**



- Power Supply : +15V/0V/-15V
- Input / Output : Transformer & Pulse Transformer
- Synchronization Voltage : 5-220V, 50/60Hz
- Control Voltage : 0-10V
- Trigger Angle : 0-30°
- Trigger Control Delay Angle : 0-180° & 180°-360°
- Pulse Output : Single Pulse, Train Pulse
- Protection : 5A Fuse With Fuse Holder
- Terminal Socket : 4mm Safety Type
- Unit Type : Panel H1

**SIX PULSE CONTROLLER  
EM-21-02-02**



- Power Supply : +15V/0V/-15V
- Input / Output : Transformer & Pulse Transformer
- Synchronization Voltage : 5-400V, 50/60Hz
- Control Voltage : 0-10V
- Trigger Angle : 0-30°
- Trigger Control Delay Angle: 0-180° & 180°-360°
- Pulse Output : Single Pulse & Train Pulse
- Protection : 5A Fuse With Fuse Holder
- Terminal Socket : 4mm Safety Type
- Unit Type : Panel H2

**PWM CONTROLLER  
EM-21-02-03**



- Output: Pulse Width Modulation Isolated Pulse Output
- Frequency Variable : 0...20kHz : x1, x10, x100 (Switchable)
- Duty Ratio : 0...100% (Reverse / Forward)
- Protection : 5A Fuse With Fuse Holder
- Terminal Socket : 4mm Safety Type
- Unit Type : Panel H2

**DUTY CYCLE PHASE CONTROLLER  
EM-21-02-04**



- Power Supply : +15V/0V/-15V
- Synchronization Voltage : 5-400V,50/60Hz
- Output Phase Control : Positive and Negative
- Duty Cycle (D) : 0.00, 0.25, 0.50, 0.75, 1.00
- Protection: 5A Fuse With Fuse Holder
- Terminal Socket: 4mm Safety Type
- Unit Type : Panel H1

**RESISTIVE LOAD MODULE (I)  
EM-21-03-01**



- Configuration : STAR , DELTA
- Resistor : 3X100Ohm / 100 Watt
- Protection : 5A Fuse With Fuse Holder
- Terminal Socket : 4mm Safety Type
- Unit Type : Panel H1

**INDUCTIVE LOAD MODULE  
EM-21-03-02**



- Configuration : STAR , DELTA
- Inductor : 50mH/2.5A
- Protection : 5A Fuse With Fuse Holder
- Terminal Socket : 4mm Safety Type
- Unit Type : Panel H1

**CAPACITOR LOAD MODULE  
EM-21-03-03**



- Configuration : STAR , DELTA
- Capacitor : 0.1uF / 450V
- Protection : 5A Fuse With Fuse Holder
- Terminal Socket : 4mm Safety Type
- Unit Type : Panel H1

**RESISTOR LOAD MODULE (II)  
EM-21-03-04**



- Configuration : STAR , DELTA
- Resistor : 3x1.0 Ohm/5Watt
- Protection : 5A Fuse With Fuse Holder
- Terminal Socket : 4mm Safety Type
- Unit Type : Panel H1

**DC POWER SUPPLY MODULE  
EM-21-04-02**



- Output Type : DC Fixed Output Voltage
- Output Voltage : +15V/0/-15V
- Output Current : 2A
- Power Supply : 240V,50Hz
- Protection : Short Circuit & 5A Fuse With Fuse Holder
- Terminal Socket : 4mm Safety Type
- Unit Type : Panel H1

**CONNECTING SAFETY LEAD SET  
EM-30-15-04**



- The set consists of 2 type lead set and 2 type bridging plug set in 5 different coded colors and lengths chosen to allow the realization of all experiment manual.
- Leads are capable of 15A current safety plugs.
- Safety Terminal Socket (4mm): 25cm x 15 units; 50cm x 20 units; 100cm x 15 units
- 2mm Test Leads Set: 45cm x 12 units
- 19mm Bridging Plug Set x 14 units
- 19mm Bridging Plug Set (Stackable) x 6 units

**THREE PHASE AC POWER SUPPLY  
EM-21-04-01**

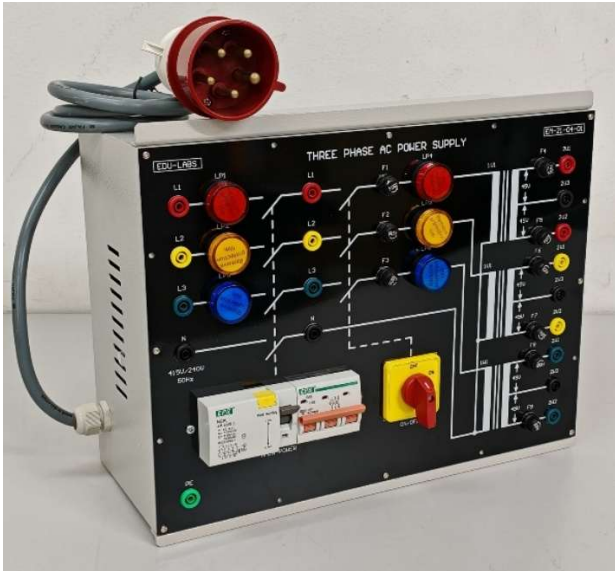

- Output Type: AC Fixed Output Voltage
- AC Input Voltage: 3x240/415V+N+PE
- Transformer Output : 3x0-45-90V
- Output Current: 2.0A
- Circuit Breaker, E.L.C.B, Power Switch, Pilot Lamp
- Protection: Short Circuit & 5A Fuse With Fuse Holder
- Terminal Socket: 4mm Safety Type
- Unit Type: Panel H4

**DIGITAL DC VOLTMETER  
EM-30-13-01**



- Modular design
- Measurement range: 0 ~ 600Vdc
- Display: 3 ½ digits 14.2 mm LED
- Accuracy:  $\pm 0.2\% \pm 1$  digit
- Resolution: 1V
- Input impedance : 1M $\Omega$
- Power source: 240Vac, 50Hz
- Unit Type: Panel H1
- Terminals: 4mm Safety Sockets

**DIGITAL DC AMMETER  
EM-30-13-02**



- Modular design
- Measurement range: DC 0 ~ 10 A
- Display: 3 ½ digits 14.2 mm LED
- Accuracy:  $\pm 0.3\% \pm 1$  digit
- Resolution: 0.01 A
- Input impedance: < 0.1 $\Omega$
- Power source: 240Vac, 50Hz
- Unit Type: Panel H1
- Terminals: 4mm Safety Sockets

**DIGITAL AC VOLTMETER  
EM-30-13-03 (2 UNITS)**



- Modular design
- Measurement range: 0 ~ 600Vac
- Display: 3 ½ digits 14.2 mm LED
- Accuracy:  $\pm 0.2\% \pm 1$  digit
- Resolution: 1V
- Input impedance: 1M $\Omega$
- Power source: 240Vac, 50Hz
- Unit Type: Panel H1
- Terminals: 4mm Safety Sockets

**DIGITAL AC AMMETER  
EM-30-13-04**



- Modular design
- Measurement range: AC 0 ~ 5A
- Display: 3 ½ digits 14.2 mm LED
- Accuracy:  $\pm 0.3\% \pm 1$  digit
- Resolution: 0.01 A
- Input impedance: < 0.1 $\Omega$
- Power source: 240Vac, 50Hz
- Unit Type: Panel H1
- Terminals: 4mm Safety Sockets

**DC SHUNT WOUND MOTOR  
EM-30-01-01**



- Nominal Power: 180W (1/4HP)
- Nominal Voltage: 220VDC
- Nominal Current: 1.50 A
- Nominal Speed: 1500 rpm
- Cooling Method: Self Cooled
- Terminals: 4mm Safety Socket
- Base Plate: Attachable To Break Load Unit
- Coupling: EM-21-CS

**THREE PHASE INDUCTION MOTOR  
EM-30-02-01**



- Nominal Power: 180W (1/4HP)
- Nominal Voltage: 240VAC / 415VAC (Delta/Star)
- Nominal Current: 1.15 / 0.95A (Delta/Star)
- Nominal Speed: 1500 rpm
- Cooling Method: Total Enclosed Fan Cooled
- Terminals: 4mm Safety Socket
- Base Plate: Attachable To Break Load Unit
- Coupling: EM-21-CS

## THREE PHASE POWER QUALITY METER (ETHERNET PORT) EM-30-13-16



- Modular design
- Display Type: HD LCD Display
- Real-Time Measurement
  - Phase voltage: V1, V2, V3, Vlnavg Line voltage: V12, V23, V31, Vllavg Current: I1, I2, I3, Iavg, In Active power: per phase and total active power Reactive power: per phase and total reactive power Apparent power: per phase and total apparent power Power factor: per phase and total power factor Total frequency
- Energy And Demand
  - Four quadrant active energy: Import, Export, Total, Net Four quadrant reactive energy: Import, Export, Total, Net Active, Reactive, Apparent demand

- Power Quality Analysis
  - Voltage unbalance Current unbalance Voltage THD (Total harmonic distortion), Odd-even harmonic distortion Voltage individual harmonics, Crest factor Current THD, Odd-even harmonic distortion Current individual harmonics, K factor
- Communication
  - **Ethernet 10/100M network port**
  - RS485 communication port
  - MODBUS RTU communication protocol
- Trend Logging
  - Phase voltage Line voltage Current Active power Reactive power Apparent power Power factor Frequency Three-phase unbalance Active energy Reactive energy Apparent energy Phase
- Settable Logging Interval
  - Logging from 1min to 60min, interval settable
- Software Accessibility
  - 4 Tariffs (DataLog) Sharp, peak, flat, valley in different season and schedule (TOU)
- **POWER MANAGEMENT SOFTWARE** interface
- Accuracy:  $\pm 0.5\%$
- Protection: Fuse
- Power Supply: AC240VAC, 50Hz
- Terminals: 4mm Safety Socket
- Unit Type : Panel H2

## POWER MANAGEMENT SOFTWARE EM-30-13-16-PMS

Readings		Parameters	
<b>Real Time Metering</b>			
U1	239.78V	U12	416.15V
U2	241.46V	U23	420.78V
U3	243.35V	U31	418.04V
Ulnavg	241.50V	Ullavg	418.29V
I1	0.8756kA	Q1	0.0000kvar
I2	0.8768kA	Q2	0.0000kvar
I3	0.8776kA	Q3	0.0000kvar
Psum	0.2296kVA	Qsum	0.0000kvar
PF1	0.9999	Freq	49.967Hz
PF2	0.9999	In	0.0000A
PF3	0.9999	Uunbalance	1.51%
PFsum	0.9999	Iunbalance	0.82%
AngleU1	0.00°	AngleU2	240.26°
AngleI1	359.97°	AngleI2	240.26°
DemandP	0.0000kVA	DemandQ	0.0000kvar
DemandS	0.0000kVA		

- PC software for power quality meter
- True-RMS measuring parameters
- ANSI and IEC 0.2 accuracy class
- Power quality analysis
- 4 quadrant energy
- Data logging
- Measure individual harmonics from 2<sup>nd</sup> to 49<sup>th</sup>
- TOU, 4 Tariffs, 6 Seasons, 6 Schedules
- Complete with **Ethernet 10/100M network cable**

**EXPERIMENTAL TABLE  
EM-30-16-01-03D**



- Workbench Table Top
- Material: Compress Board
- Dimension:
  - Thickness: 25mm
  - Length: 1500mm
  - Width: 800mm
  - Height: 800mm
- Support Structure
- Material:
  - 2' x 2' Hollow Steel Epoxy Coated
  - Thickness: 2mm
- Lower Cabinet with 3 Storage Drawers with center Lock
- Castor Wheels (Front With Lock)

**EXPERIMENT PANEL FRAME  
EM-30-16-02-02**



- Din Standard A4 With Two Shelves
- Side Frame: T Shape
- Horizontal U-Bar: Top and Bottom
- Horizontal H-Bar: Centre
- Material: 2mm Thickness Steel Epoxy Coated
- Dimension:
  - Length: 1450mm
  - Width: 20mm
  - Height: 300mm
- Complete with Test Lead Set Holder
  - Two Location: Left & Right
  - 7 Slots for 4mm Stackable Safety Test Lead Sets

**POWER ELECTRONICS TRAINER EM-21800QM - OBJECTIVE & EXPERIMENTS LIST**

**Experiment 1: Power Diode**

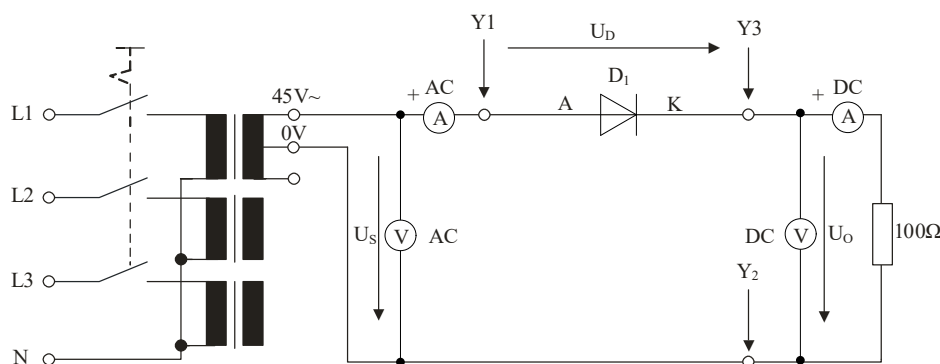

**Objectives: the trainee is able to**

1. Describe the principle of power diode within the alternating-current circuit.
2. Determine the characteristic of power diode.
3. Determine the shape of the voltage-current characteristic curve within the alternating-current circuit for resistive load.
4. Determine the form factor.

**Experiments Lists**

1. Experiment 1.1: Voltage and current characteristic

- Experiment 1.2: Determination of the shape of the voltage-current characteristic curve
- Experiment 1.3: Determine the form factor

### Experiment 2: Thyristor (SCR)

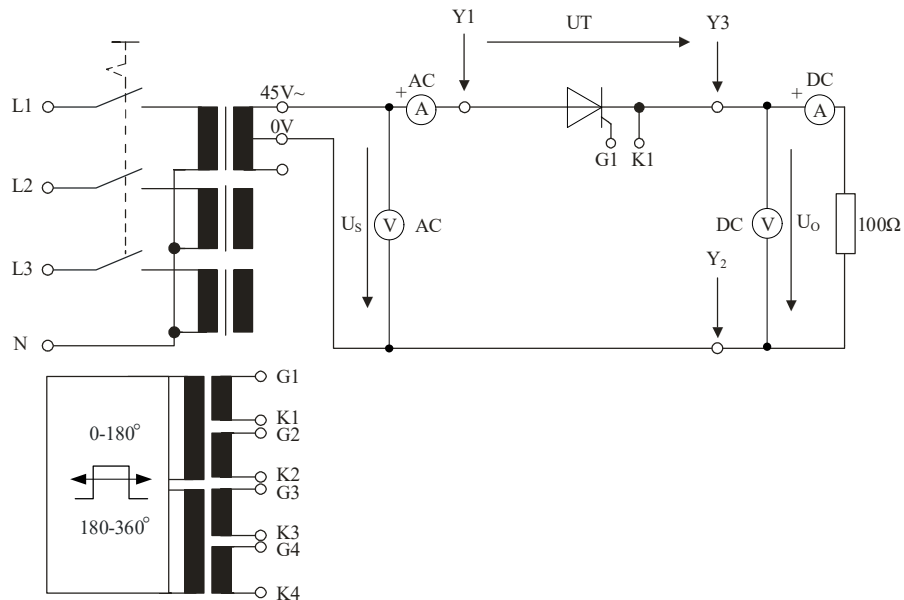

#### **Objectives: the trainee is able to**

- Determine the shape of SCR characteristic curve
- Describe the controlling of SCR
- Calculate the average and RMS value of output voltage
- Explain the correlation between phase angle of the firing pulse and output voltage

#### **Experiments List**

- Experiment 2.1: Voltage and current characteristic of SCR
- Experiment 2.2: Determination of the shape of the voltage-current characteristic curve of SCR

### Experiment 3: Triac

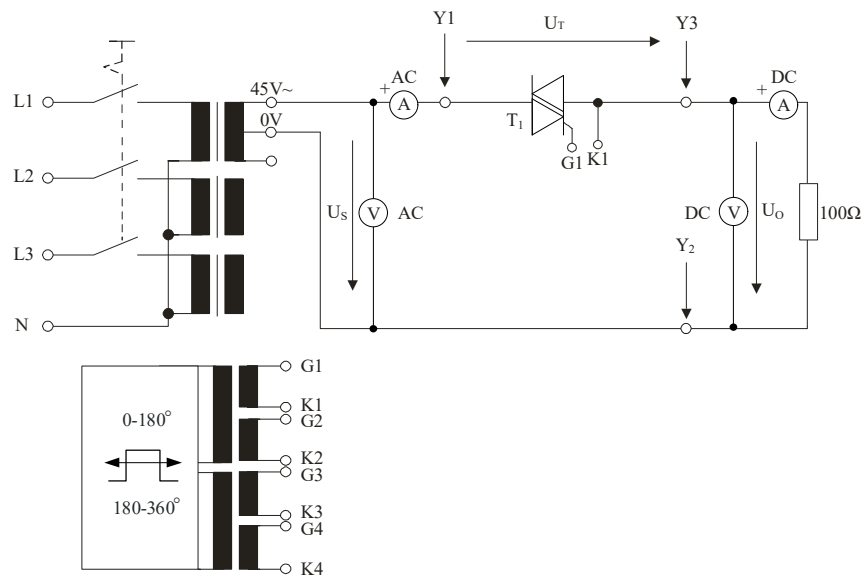

#### **Objectives: the trainee is able to**

- Determine the characteristic of triac
- Measure the voltage in triac circuit
- Describe the principle of triac

## Experiments List

1. Experiment 3.1: Characteristic of Triac
2. Experiment 3.2: Control of the current

## Experiment 4: Single Phase Half-Wave Rectifier

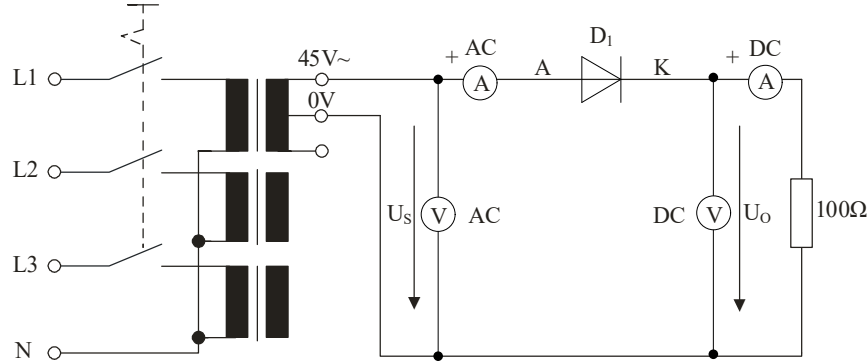

### Objectives: the trainee is able to

1. Determine the voltage ratio for resistive load
2. Determine the shape of the voltage-current characteristic curve for resistive load
3. Determine the current ratio for resistive load
4. Determine the ripple for resistive load
5. Determine the shape of the voltage-current characteristic curve for resistive-inductive load

### Experiments Lists

1. Experiment 4.1: Voltage Ratio for Resistive Load
2. Experiment 4.2: Voltage-Current Characteristic Curve for Resistive Load
3. Experiment 4.3: Current Ratio for Resistive Load
4. Experiment 4.4: Ripple Factor for Resistive Load
5. Experiment 4.5: Voltage-Current Characteristic Curve for Resistive-Inductive Load

## Experiment 5: Full-wave rectifier with center tap

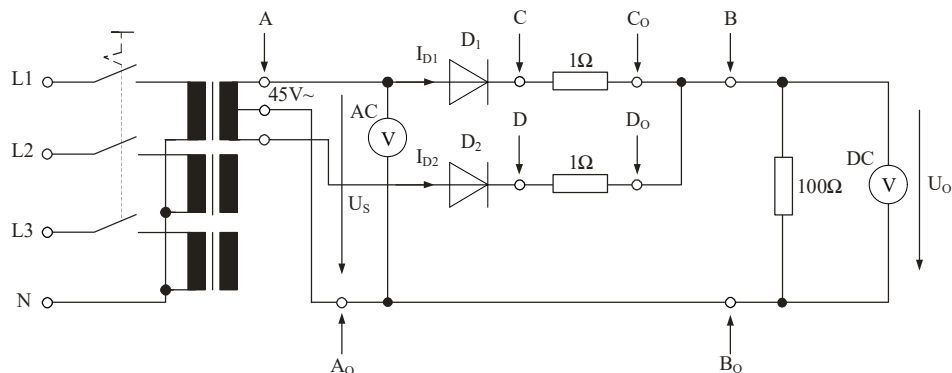

### Objectives: the trainee is able to

1. Determine the voltage ratio
2. Measure the shape of the voltage-current characteristic curve for resistive load
3. Determine the current ratio
4. Determine the ripple for resistive load
5. Measure the shape of the voltage-current characteristic curve for resistive-inductive load

### Experiments Lists

1. Experiment 5.1: voltage ratio for resistive load
2. Experiment 5.2: voltage-current characteristic curve for resistive load
3. Experiment 5.3: current ratio for resistive load
4. Experiment 5.4: Ripple factor for resistive load
5. Experiment 5.5: Voltage-current characteristic curve for resistive-inductive load

## Experiment 6: Single Phase Full-Wave Bridge Rectifier

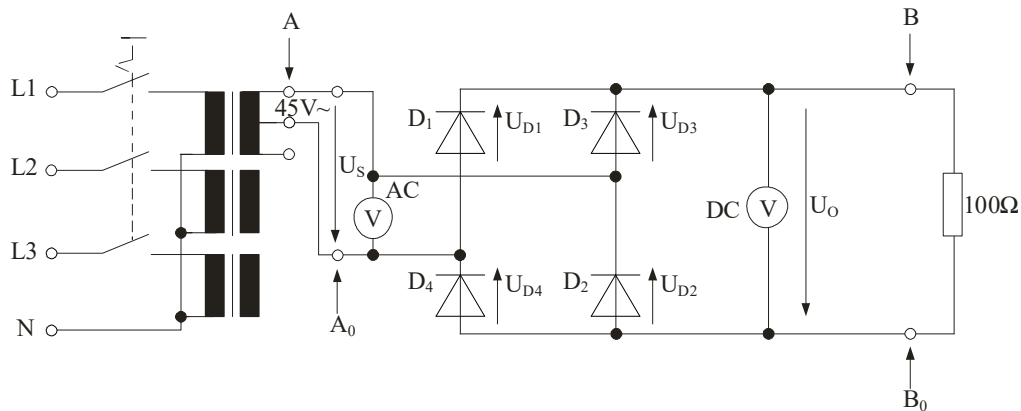

### Objectives: the trainee is able to

1. Determine the voltage ratio for resistive load
2. Measure the diode voltage drop
3. Measure the shape of the current characteristic curve for resistive load
4. Determine the current ratio for resistive load
5. Determine the voltage factor for resistive load
6. Measure the shape of the voltage-current characteristic curve for resistive-inductive load

### Experiments list:

1. Experiment 6.1: voltage ratio for resistive load
2. Experiment 6.2: Voltage drop on diode
3. Experiment 6.3: The shape of diode conducting current curve for resistive load
4. Experiment 6.4: Current ratio for resistive load
5. Experiment 6.5: Ripple factor for resistive load
6. Experiment 6.6: Voltage-current characteristic curve for resistive-inductive load

## Experiment 7: Three Phase Half-Wave Rectifier

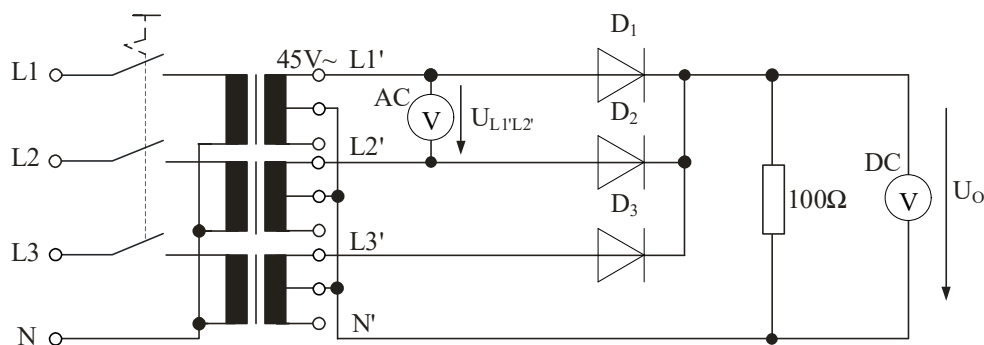

### Objectives: the trainee is able to

1. Determine the voltage ratio for resistive load
2. Measure the shape of the current characteristic curve for resistive load
3. Determine the current ratio for resistive load
4. Determine the ripple factor for resistive load
5. Measure the shape of the voltage-current characteristic curve for resistive-inductive load

### Experiments Lists

1. Experiment 7.1: voltage ratio for resistive load
2. Experiment 7.2: Voltage-current characteristic curve for resistive load
3. Experiment 7.3: Current ratio for resistive load
4. Experiment 7.4: Ripple factor
5. Experiment 7.5: Voltage-current characteristic curve for resistive-inductive load

## Experiment 8: Three Phase Full-Wave Tap Rectifier

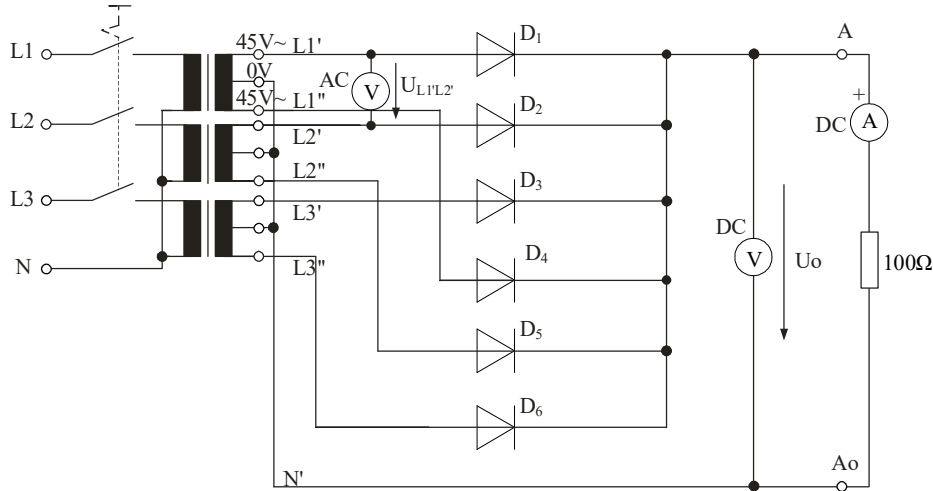

### Objectives: The trainee is able to

1. Determine the voltage ratio for resistive load
2. Measure the shape of the voltage-current characteristic curve for resistive load
3. Determine the current ratio for resistive load
4. Determine the ripple factor for resistive load
5. Measure the shape of the voltage-current characteristic curve for resistive-inductive load

### Experiment Lists

1. Experiment 8.1: Voltage Ratio for Resistive Load
2. Experiment 8.2: Voltage and Current Characteristic Curve for Resistive Load
3. Experiment 8.3: Current Ratio for Resistive Load
4. Experiment 8.4: Ripple Factor
5. Experiment 8.5: Voltage-Current Characteristic Curve for Resistive-Inductive Load

## Experiment 9: Three Phase Full-Wave Bridge Rectifier

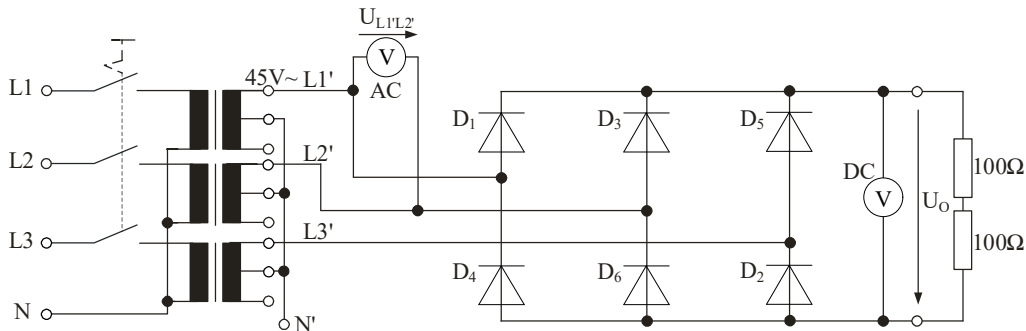

### Objectives: the trainee is able to

1. Determine the voltage ratio for resistive load
2. Measure the shape of the voltage-current characteristic curve for resistive load
3. Determine the current ratio for resistive load
4. Determine the ripple factor for resistive load
5. Measure the shape of the voltage-current characteristic curve for resistive-inductive load

### Experiments Lists

1. Experiment 9.1: Voltage ratio for resistive load
2. Experiment 9.2: Voltage characteristic curve for resistive load
3. Experiment 9.3: Current ratio for resistive load
4. Experiment 9.4: Ripple factor
5. Experiment 9.5: Voltage-current characteristic curve for resistive-inductive load

## Experiment 10: Single Phase Half-Wave Controlled Rectifier

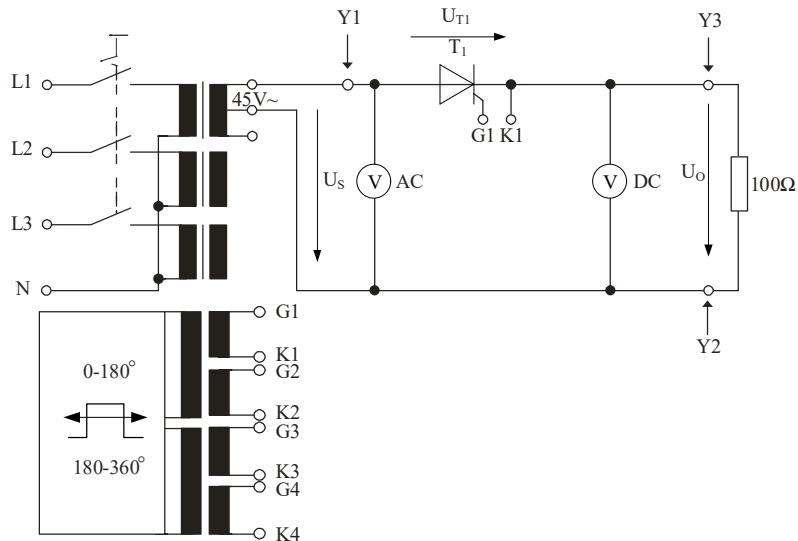

### Objectives: the trainee is able to

1. Acquaint the relations between delay angle  $\alpha$  and output voltage  $U_o$
2. Measure the shape of the voltage-current characteristic curve for resistive load
3. Measure the shape of the voltage-current characteristic curve for resistive-inductive load

### Experiments Lists

1. Experiment 10.1: The relations between delay angle  $\alpha$  and output voltage  $U_o$
2. Experiment 10.2: Voltage-current characteristic curve for resistive load
3. Experiment 10.3: Voltage-current characteristic curve for resistive-inductive load

## Experiment 11: Full-Wave Controlled Rectifier with Center Tap

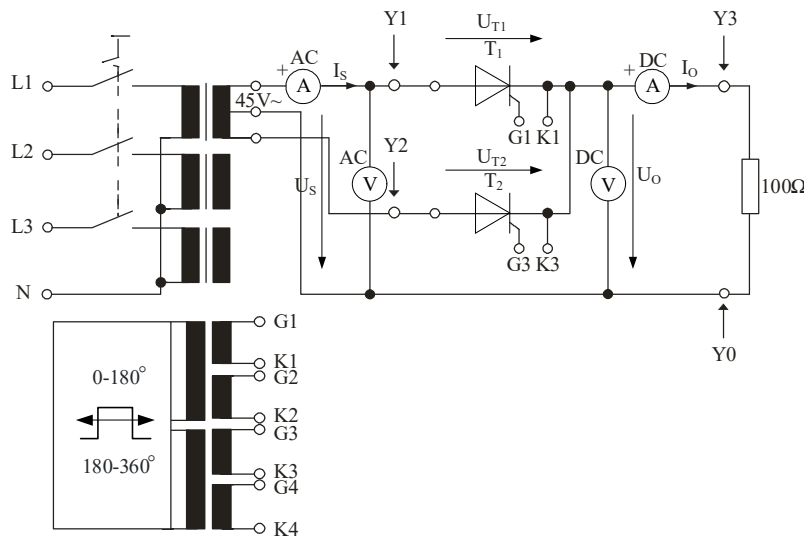

### Objectives: the trainee is able to

1. Acquaint the relations between delay angle  $\alpha$  and output voltage  $U_o$
2. Measure the shape of the voltage-current characteristic curve for resistive load
3. Measure the shape of the voltage-current characteristic curve for resistive-inductive load

### Experiments Lists

1. Experiment 11.1: The relations between delay angle  $\alpha$  and output voltage  $U_o$
2. Experiment 11.2: Voltage-current characteristic curve with resistive load
3. Experiment 11.3: Voltage-current characteristic curve for resistive-inductive load

## Experiment 12: Single Phase Full-Wave Fully Control Bridge

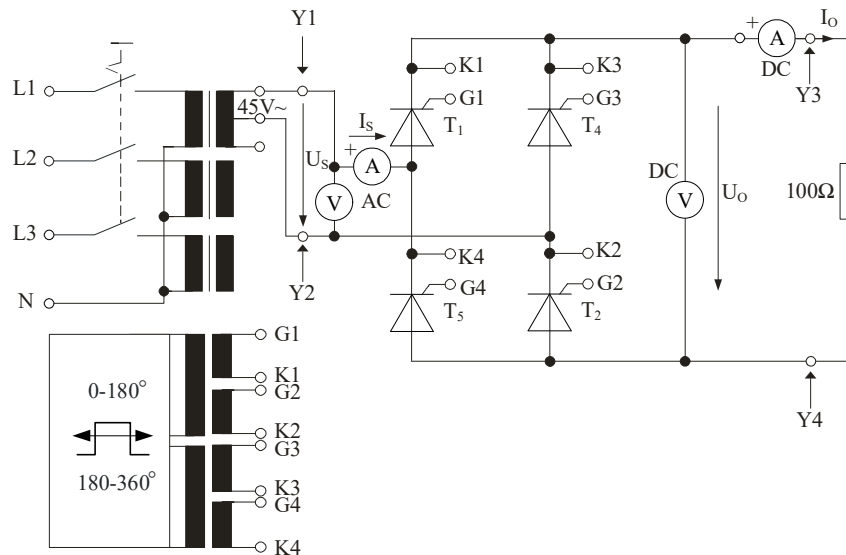

### Objectives: the trainee is able to

1. Acquaint the relations between delay angle  $\alpha$  and output voltage  $U_o$
2. Measure the shape of the voltage-current characteristic curve with resistive load
3. Measure the shape of the voltage-current characteristic curve with resistive-inductive load

### Experiments List

1. Experiment 12.1: The relations between delay angle  $\alpha$  and output voltage  $U_o$
2. Experiment 12.2: Voltage-current characteristic curve with resistive load
3. Experiment 12.3: Voltage-current characteristic curve for resistive-inductive load

## Experiment 13: Three Phase Half-Wave Control Rectifier

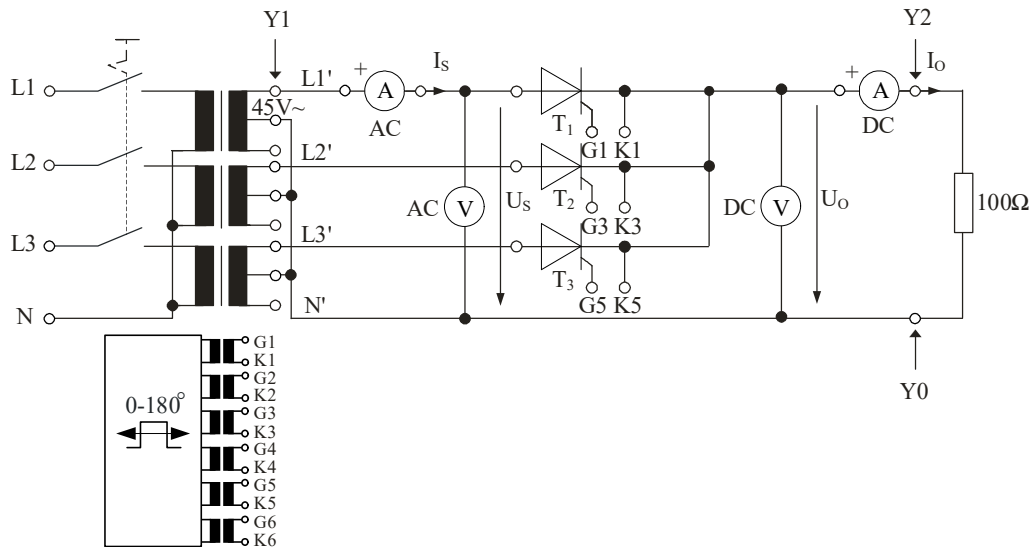

### Objectives: the trainee is able to

1. Acquaint the relations between delay angle  $\alpha$  and output voltage  $U_o$
2. Measure the shape of the voltage-current characteristic curve with resistive load
3. Measure the shape of the voltage-current characteristic curve with resistive-inductive load

### Experiments List

1. Experiment 13.1: The relations between delay angle  $\alpha$  and output voltage  $U_o$
2. Experiment 13.2: Voltage-current characteristic curve with resistive load
3. Experiment 13.3: Voltage-current characteristic curve for resistive-inductive load

## Experiment 14: Three Phase Full-wave Control Rectifier with Center Tap

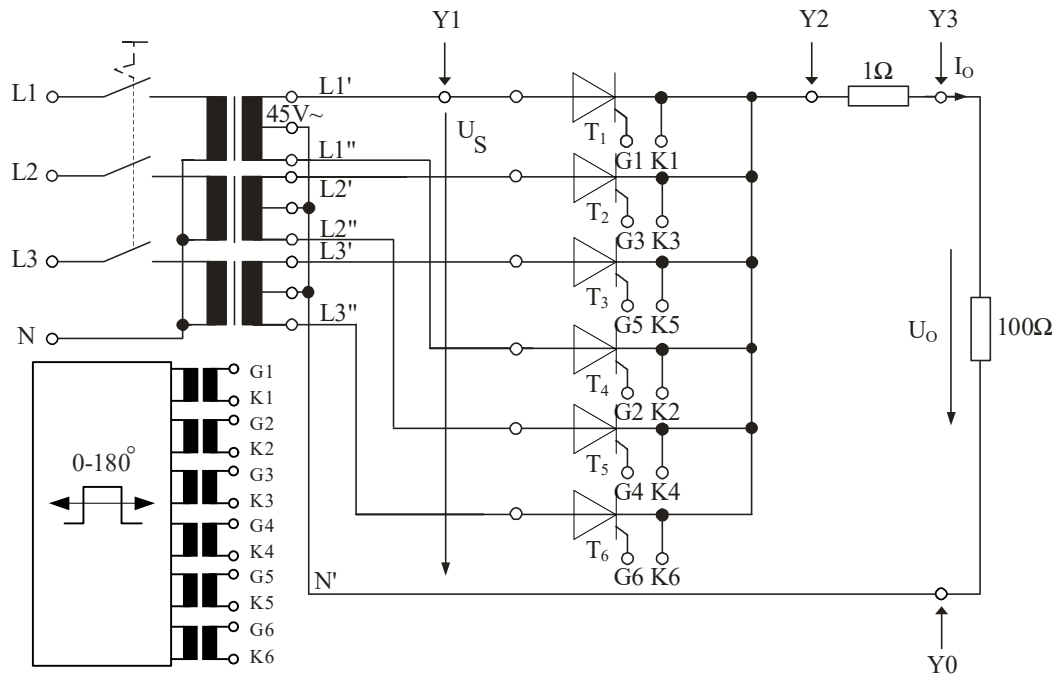

**Objectives: the trainee is able to**

1. Measure the shape of the voltage-current characteristic curve with resistive load

### Experiments List

1. Experiment 14.1: Voltage-current characteristic curve with resistive load

## Experiment 15: Three phase Full-Wave Fully-Control Bridge

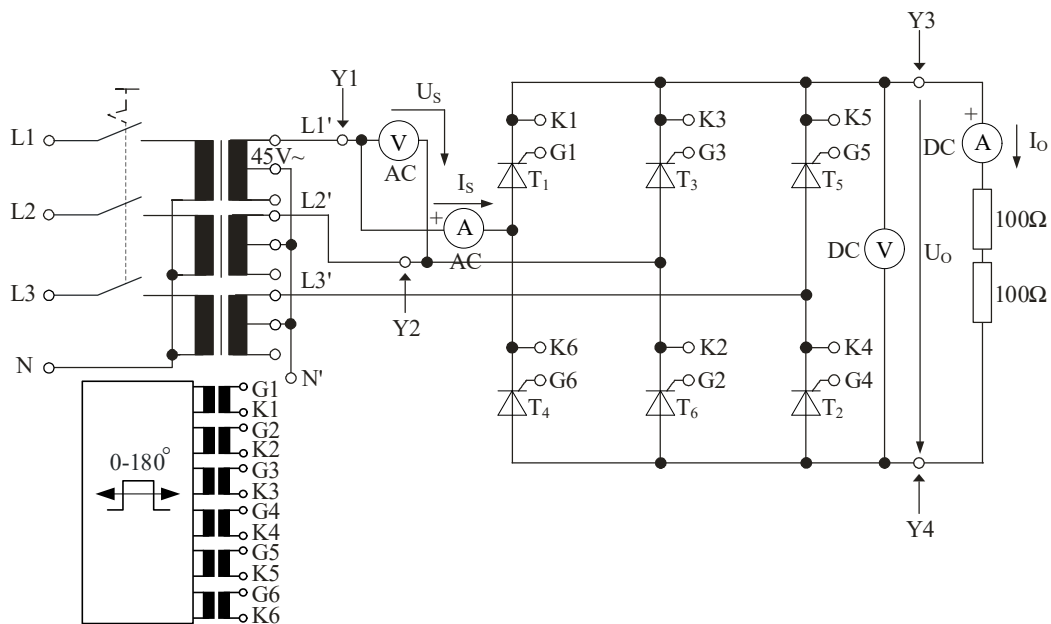

**Objectives: the trainee is able to**

1. Acquaint the relations between delay angle  $\alpha$  and output voltage  $U_o$
2. Measure the shape of the voltage-current characteristic curve with resistive load

### Experiments Lists

1. Experiment 15.1: The relations between delay angle  $\alpha$  and output voltage  $U_o$
2. Experiment 15.2: Voltage and line current characteristic curve

## Experiment 16: Single Phase Full-Wave Half Controlled Bridge

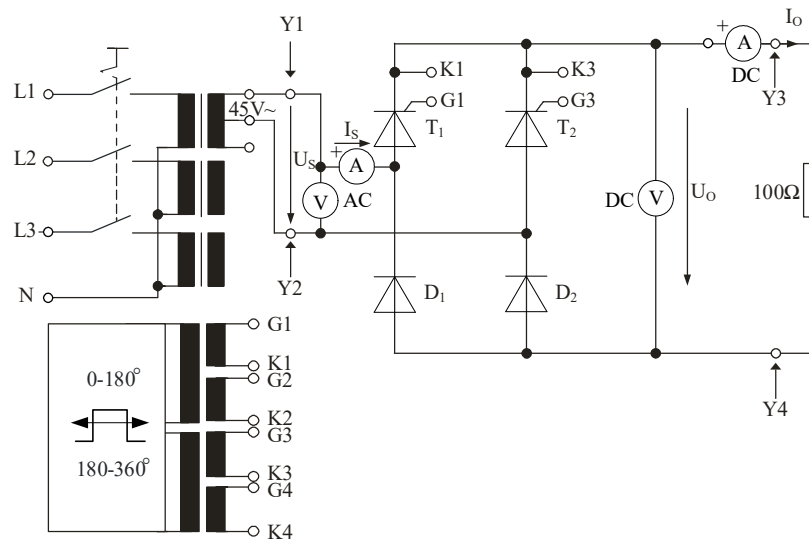

**Objectives: The trainee is able to**

1. Acquaint the relations between delay angle  $\alpha$  and output voltage  $U_o$
2. Measure the shape of the voltage-current characteristic curve with resistive load
3. Measure the shape of the voltage-current characteristic curve with resistive-inductive load

### Experiments Lists

1. Experiment 16.1: The relations between delay angle  $\alpha$  and output voltage  $U_o$
2. Experiment 16.2: Voltage- current characteristic curve
3. Experiment 16.3: Voltage-current characteristic curve for resistive-inductive load

## Experiment 17: Three Phase Full-wave Half Control Bridge

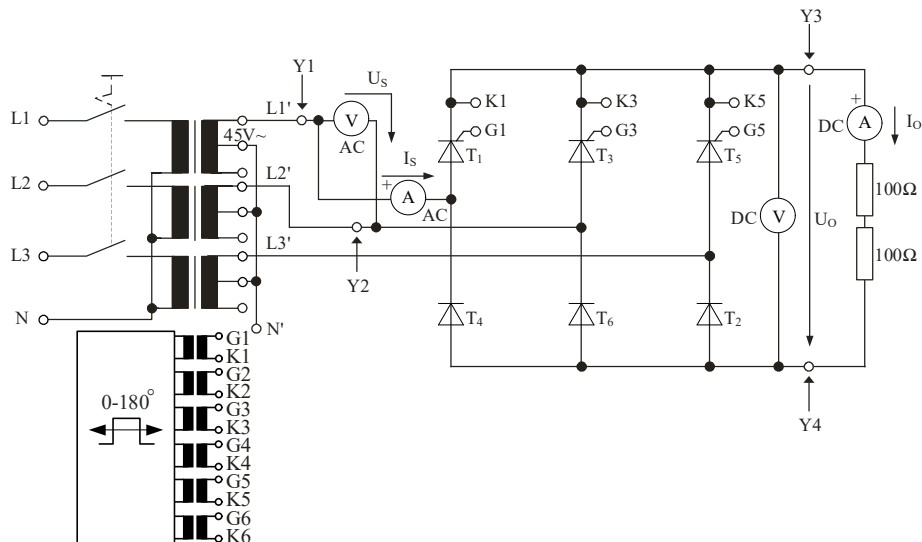

**Objectives: the trainee is able to**

1. Acquaint the relations between delay angle  $\alpha$  and output voltage  $U_o$
2. Measure the shape of the voltage-current characteristic curve with resistive load
3. Measure the shape of the voltage-current characteristic curve with resistive-inductive load

### Experiments Lists

1. Experiment 17.1: The relations between delay angle  $\alpha$  and output voltage  $U_o$
2. Experiment 17.2: Voltage-current characteristic curve with resistive load
3. Experiment 17.3: Voltage and line current characteristic curve for resistive-inductive load
4. Experiment 17.4: SCR current characteristic curve for resistive-inductive load

## Experiment 18: Single Phase Bidirectional Connection On Resistive Load

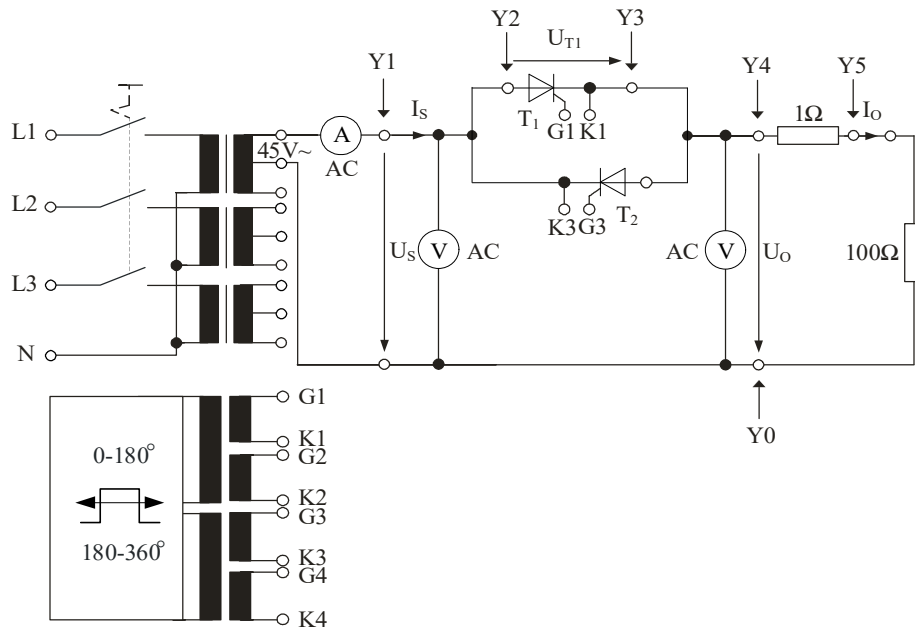

### Objectives: the trainee is able to

1. Determine the shape of the voltage and current characteristic curve at the converter on resistive load
2. Measure the shape of the SCR current characteristic curve on resistive load
3. Examine the phase control of triac
4. Indicate the control function of  $U_{o(\alpha)}/U_o = f(\alpha)$  and  $P_{o(\alpha)}/P_o = f(\alpha)$

### Experiments List

1. Experiment 18.1: Voltage- current characteristic curve on resistive load
2. Experiment 18.2: SCR current characteristic curve on resistive load
3. Experiment 18.3: Phase control of triac

## Experiment 19: Delta-Connected Three Phase Bi-direction Connection

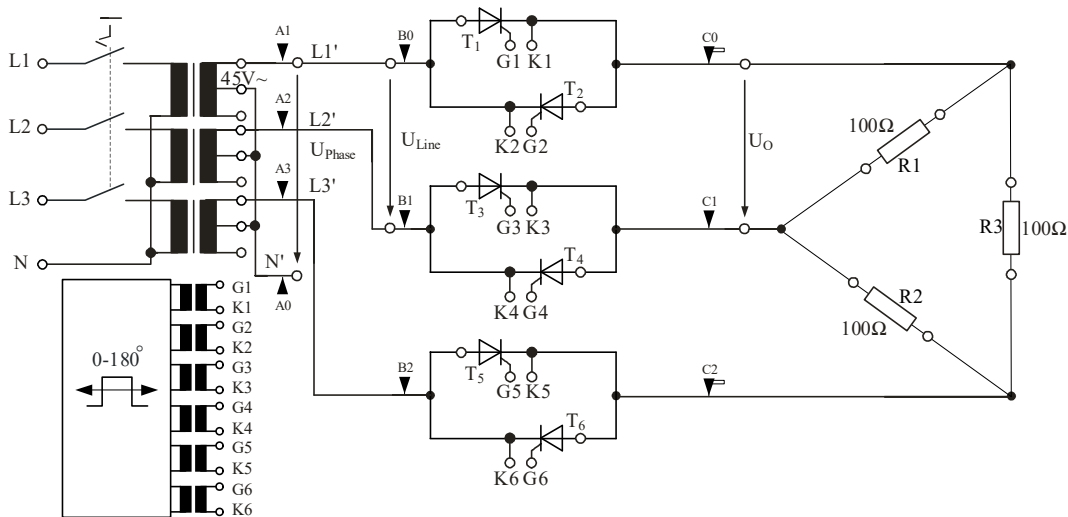

### Objectives: the trainee is able to

1. Experiment 19.1: Determine the phase control characteristic of the delta-connected three phase bidirectional connection on resistive load
2. **Experiment 19.2: Determine the phase control characteristic of the delta-connected three phase bidirectional connection on Three Phase Induction Motor**

## Experiment 20: Star-Connected Three Phase Bidirectional Connection

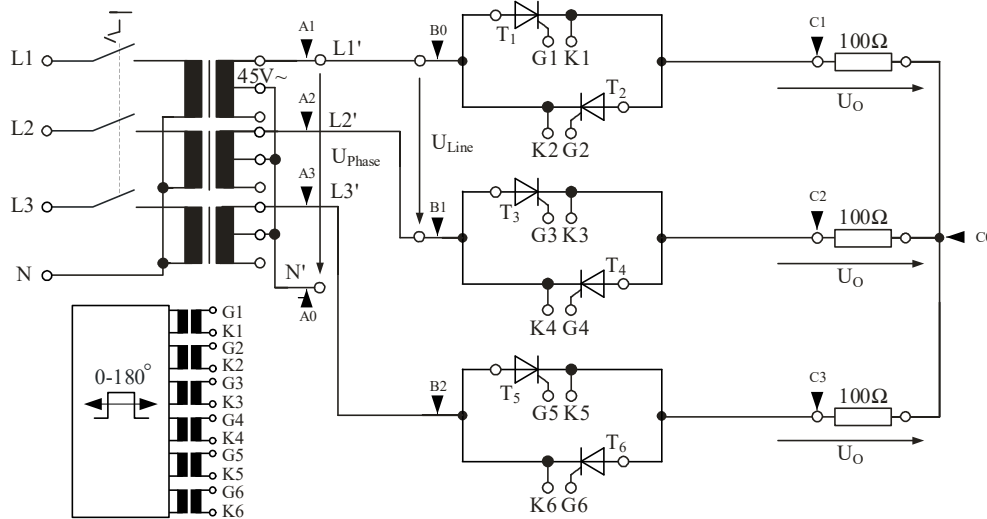

**Objectives: the trainee is able to**

1. Experiment 19.1: Determine the phase control characteristic of the star-connected three phase bidirection connection on resistive load
2. **Experiment 19.2: Determine the phase control characteristic of the star-connected three phase bidirectional connection on Three Phase Induction Motor**

## Experiment 21: PWM Generation Circuit

**Objectives: The trainee is able to**

1. Examine the produced waveform of the PWM Controller

**Experiment Lists**

2. Experiment 21.1: PWM Generation Circuit

## Experiment 22: IGBT Chopper Circuit

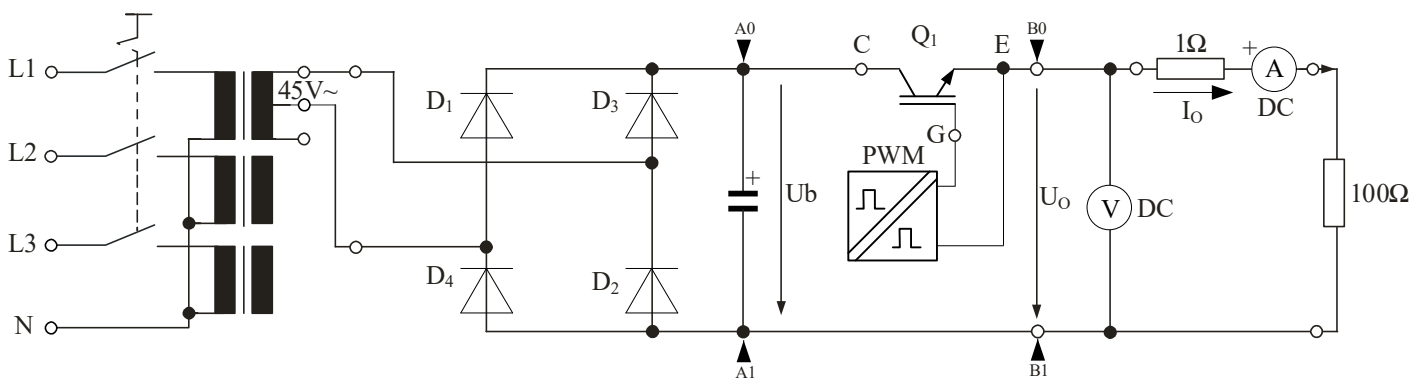

**Objectives: the trainee is able to**

1. Acquaintance the principle of chopper circuit
2. Indicate the relationship of  $V_o = f(\text{Duty Cycle})$
3. Measure the voltage and current
4. Determine the relationship between ripple current and pulse width

**Experiments list :**

1. Experiment 22.1: The relationship of  $V_o = f(\text{Duty Cycle})$  in IGBT chopper circuit
2. Experiment 22.2: The voltage-current characteristic curve in IGBT chopper circuit
3. Experiment 22.3: The relationship between ripple current and pulse width
4. Experiment 22.4: The relationship between ripple current and frequency

## Experiment 23: MOSFET Chopper Circuit

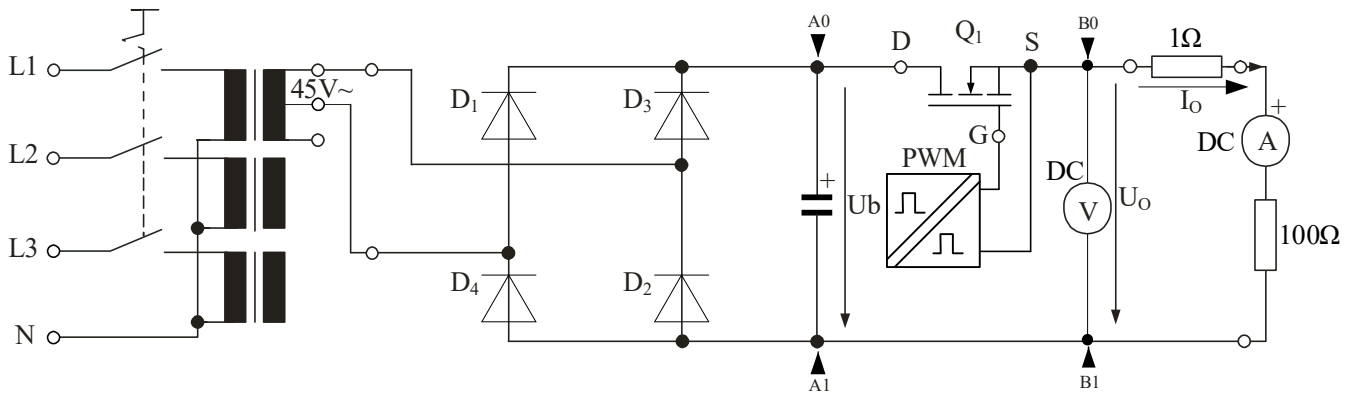

### Objectives: The trainee is able to

1. Acquaintance the principle of chopper circuit
2. Indicate the relationship of  $V_o = f(\text{Duty Cycle})$  in MOSFET chopper circuit
3. Measure the voltage and current
4. Determine the relations between ripple current and pulse width

### Experiment Lists

1. Experiment 23.1: The relationship of  $V_o = f(\text{Duty Cycle})$  in MOSFET chopper circuit
2. Experiment 23.2: The voltage-current characteristic curve in MOSFET chopper circuit
3. Experiment 23.3: The relationship between ripple current and pulse width
4. Experiment 23.4: The relationship between ripple current and frequency

## Experiment 24: Darlington Transistor Chopper Circuit

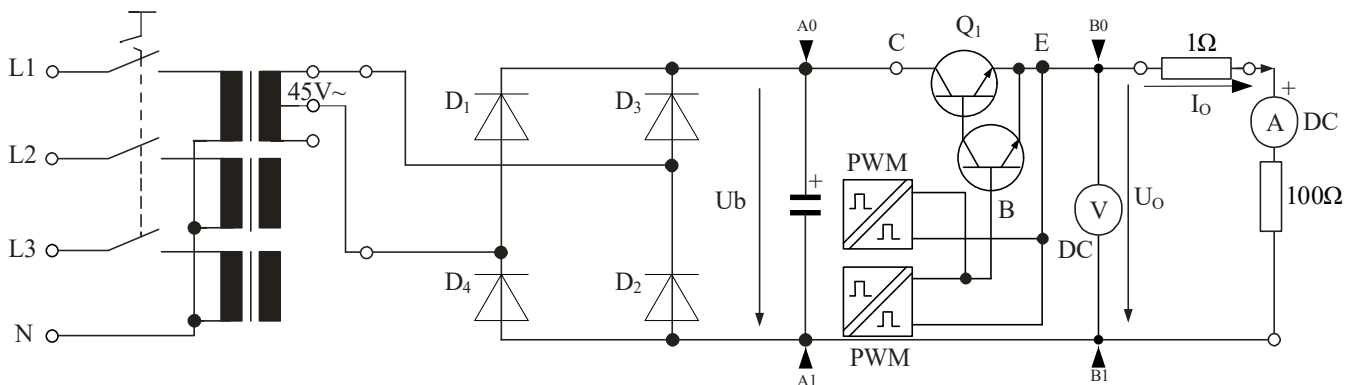

### Objectives: The trainee is able to

1. Acquaintance the principle of chopper circuit
2. Indicate the relationship of  $V_o = f(\text{Duty Cycle})$  in Darlington transistor chopper circuit
3. Measure the voltage and current
4. Determine the relations between ripple current and pulse width

### Experiment Lists

1. Experiment 24.1: The relationship of  $V_o = f(\text{Duty Cycle})$  in darlington transistor chopper circuit
2. Experiment 24.2: The voltage-current characteristic curve in darlington transistor chopper circuit
3. Experiment 24.3: The relationship between ripple current and pulse width
4. Experiment 24.4: The relationship between ripple current and frequency

## Experiment 25: Cycloconverters

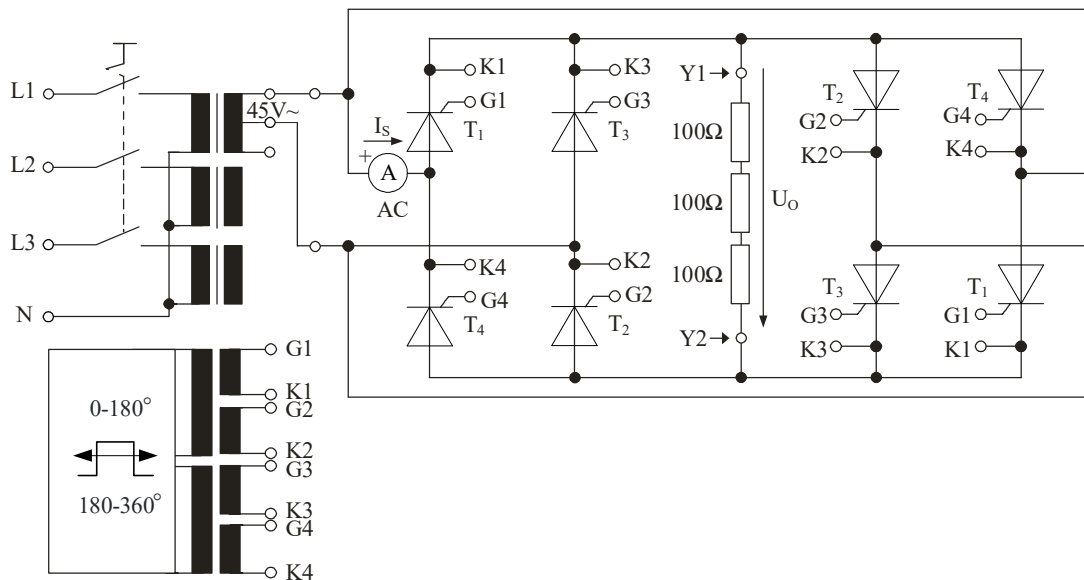

### Objectives: the trainee is able to

1. Acquaintance the principle of cycloconverters
2. Measure the output voltage on resistive load

### Experiments Lists

1. Experiment 25.1: Acquaintance the principle of cycloconverters and measure the output voltage on resistive load

## Experiment 26: H-Bridge Converter

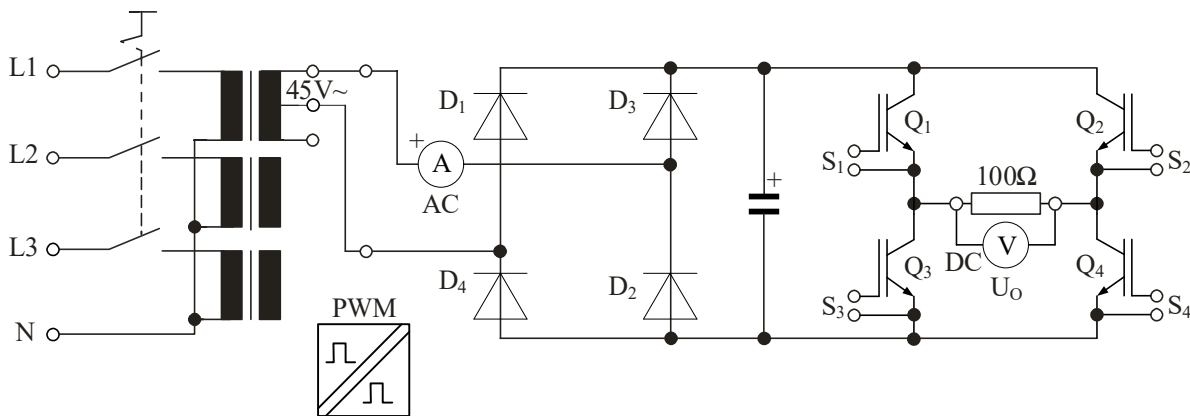

### Objectives: The trainee is able to

1. Acquaintance the principle of H-Bridge converter
2. Measure the quantities and direction of output voltage and current

### Experiments Lists

1. Experiment 26.1: The output voltage of H-Bridge converter
2. Experiment 26.2: The output current of H-Bridge converter
3. Experiment 26.3: The DC Motor Control of H-Bridge converter

**Note:** Layout and specification may change without prior notices for products continuous development and improvement process.